

双排球式回转支承(02系列)--外齿式

Double row ball type slewing bearing (02 Series) - External gear type

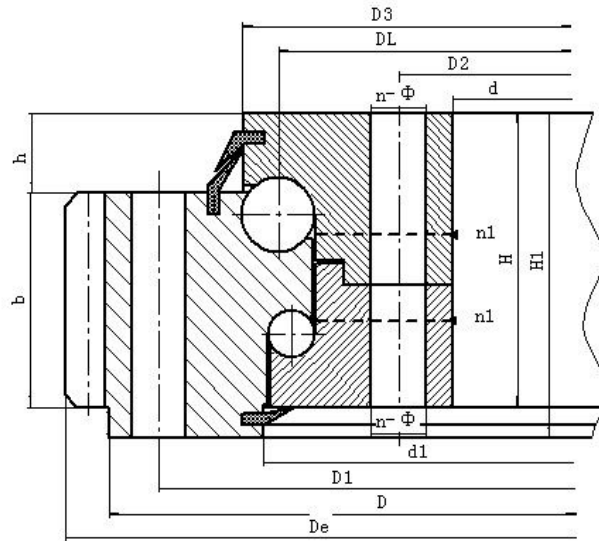

021.022

序号 Serial Number	外齿式 External gear type	外型尺寸 Boundary dimension			安装尺寸Mounting Dimensions				结构尺寸 Structure dimension				齿轮参数Gear parameter				齿轮圆周力 Gear circumferential force		参考 Refere nce
	DL																正火 Normal izing		调质 Tempe ring
	mm	D	d	H	D1	D2	n	mm	n1	H1	h	b	x	m	De	z	Z 104N	T 104N	kg
		mm	mm	mm	mm	mm			mm	mm	mm	mm		mm	mm				
1	021.25.500	616	384	106	580	420	20	18	4	96	26	60	0.5	5	644	126	3.7	5.2	100
	6													646.8	105	4.5	6.2		
2	021.25.560	676	444	106	640	480	20	18	4	96	26	60	0.5	5	704	138	3.7	5.2	115
	6													706.8	115	4.5	6.2		
3	021.25.630	746	514	106	710	550	24	18	4	96	26	60	0.5	6	790.8	129	4.5	6.2	130
	8													790.4	96	6	8.3		
4	021.25.710	826	594	106	790	630	24	18	4	96	26	60	0.5	6	862.8	141	4.5	6.2	140
	8													862.4	105	6	8.3		
5	021.30.800	942	658	124	898	702	30	22	6	114	29	80	0.5	8	982.4	120	8	11.1	200
	10													988	96	10	14		
6	021.30.900	1042	758	124	998	802	30	22	6	114	29	80	0.5	8	1086.4	133	8	11.1	250
	10													1088	106	10	14		
7	021.30.1000	1142	858	124	1098	902	36	22	6	114	29	80	0.5	10	1198	117	10	14	300
	12													1197.6	97	12	16.7		
	021.30.1120													10	1318	129	10	14	

8	022.30.1120	1262	978	124	1218	1022	36	22	6	114	29	80	0.5	12	1317.6	107	12	16.7	340
9	021.40.1250	1426	1074	160	1374	1126	40	26	5	150	39	90	0.5	12	1497.6	122	13.5	18.8	580
	14													1495.2	104	15.8	21.9		
10	021.40.1400	1576	1224	160	1524	1272	40	26	5	150	39	90	0.5	12	1641.6	134	13.5	18.8	650
	14													1649.2	115	15.8	21.9		
11	021.40.1600	1776	1424	160	1724	1476	45	26	5	150	39	90	0.5	14	1845.2	129	15.8	21.9	750
	16													1852.8	113	18.1	25		
12	021.40.1800	1976	1624	160	1924	1676	45	26	5	150	39	90	0.5	14	2055.2	144	15.8	21.9	820
	16													2060.8	126	18.1	25		
13	021.50.2000	2215	1785	190	2149	1851	48	33	8	178	47	120	0.5	16	2300.8	141	24.1	33.3	1150
	18													2300.4	125	27.1	37.5		
14	021.50.2240	2455	2025	190	2389	2091	48	33	8	178	47	120	0.5	16	2540.8	156	24.1	33.3	1500
	18													2552.4	139	27.1	37.5		
15	021.50.2500	2715	2285	190	2649	2351	56	33	8	178	47	120	0.5	18	2804.4	153	27.1	37.5	1700
	20													2816	138	30.1	41.8		
16	021.50.2800	3015	2585	190	2949	2651	56	33	8	178	47	120	0.5	18	3110.4	170	27.1	37.5	1900
	20													3116	153	30.1	41.8		
17	021.60.3150	3428	2872	226	3338	2962	56	45	8	214	56	150	0.5	20	3536	174	37.7	52.2	3300
	22													3537.6	158	41.5	57.4		
18	021.60.3550	3828	3272	226	3738	3362	56	45	8	214	56	150	0.5	20	3936	194	37.7	52.2	3700
	22													3933.6	176	41.5	57.4		
19	021.60.4000	4278	3722	226	4188	3812	60	45	10	214	56	150	0.5	22	4395.6	197	41.5	57.4	4200
	25													4395	173	47.1	65.2		
20	021.60.4500	4778	4222	226	4688	4312	60	45	10	214	56	150	0.5	22	4879.6	219	41.5	57.4	4700
	25													4895	193	47.1	65.2		

注：

- 1、n1为润滑油孔数，均布：油杯M10×1 JB/T7940.1-JBT7940.2
- 2、安装孔n-dn1、n-dn2可改用螺孔；齿宽b可改为H-h。
- 3、表内齿轮圆周力为最大圆周力，额定圆周力取其1/2。
- 4、外齿修顶系数0.1。