

单盘四点接触球式回转支承 (Q系列) --内齿式

Single row four-point contact ball slewing bearing (Q series) --Internal gear type

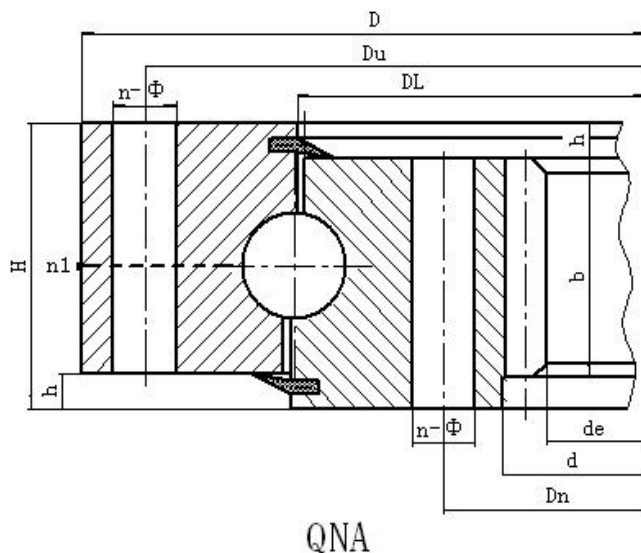

序号 Serial Number	型号 Model	安装孔尺寸 Mounting Hole Size									结构尺寸 Structure dimension			齿轮参数 Gear parameter			
		内齿式 Internal gear type		H	Du	Dn	n	通孔 through-hole	螺孔 screw B/C/D		n1油杯 oil cup 数量 quantity	h	B	m	内齿式 Internal gear type x=+0.5		
		D	d						phi	d1					T	de	齿数 z gear number
		mm									mm			mm	mm	kg	
1	QN. 315. 20	408	224	60	370	260	10	17	M16	24	2	10	40	3	207	70	34
	4													200	51	35	
2	QN. 355. 20	448	264	60	410	300	10	17	M16	24	2	10	40	3	246	84	39
	4													240	61	40	
3	QN. 400. 20	493	310	60	455	345	12	17	M16	24	2	10	40	4	288	73	44
	5													280	57	46	
4	QN. 450. 20	543	360	60	505	395	12	17	M16	24	2	10	40	4	336	85	50
	5													330	67	52	
5	QN. 500. 20	593	410	60	555	445	14	17	M16	24	2	10	40	5	385	78	55
	6													378	64	57	
6	QN. 560. 20	650	480	60	610	500	14	17	M16	24	2	10	50	4	440	111	76

6	QN. 560. 20A	656	468	70	618	502	14	17	M16	30	2	10	50	5	435	88	77
7	QN. 630. 20	726	538	70	688	572	16	17	M16	30	2	10	50	4	512	129	84
	5													505	102	86	
8	QN. 710. 20	806	618	70	768	652	18	17	M16	30	2	10	50	5	585	118	97
	6													582	98	97	
9	QN. 800. 20	896	708	70	858	742	20	17	M16	30	2	10	50	6	672	113	110
	8													664	84	111	
10	QN. 800. 25	908	694	78	864	736	18	22	M20	36	2	10	58	6	654	110	142
	8													648	82	142	
11	QN. 900. 25	1008	794	78	964	836	20	22	M20	36	2	10	58	8	744	94	163
	10													740	75	162	
12	QN. 1000. 25	1108	894	78	1064	936	24	22	M20	36	2	10	58	8	848	107	178
	10													840	85	179	
13	QN. 1000. 32	1124	880	90	1074	926	24	24	M22	40	2	10	70	8	832	105	230
	10													830	84	227	
14	QN. 1120. 32	1244	1000	90	1194	1046	28	24	M22	40	4	10	70	10	940	95	263
	12													936	79	262	
15	QN. 1250. 32	1374	1130	90	1324	1176	32	24	M22	40	4	10	70	10	1070	108	294
	12													1068	90	290	
16	QN. 1400. 32	1524	1280	90	1474	1326	36	24	M22	40	4	10	70	12	1212	102	333
	14													1204	87	336	
17	QN. 1250. 40	1394	1110	102	1336	1164	32	26	M24	45	4	12	80	10	1050	106	388
	12													1044	88	388	
18	QN. 1400. 40	1544	1260	102	1486	1314	36	26	M24	45	4	12	80	12	1188	100	444
	14													1190	86	434	
19	QN. 1600. 40	1744	1460	102	1686	1514	40	26	M24	45	4	12	80	12	1392	117	509
	14													1386	100	511	
20	QN. 1800. 40	1944	1660	102	1886	1714	44	26	M24	45	4	12	80	14	1582	114	576
	16													1568	99	591	
21	QN. 1600. 50	1766	1438	124	1704	1496	40	30	M27	50	4	12	100	12	1368	115	714
	14													1358	98	723	
22	QN. 1800. 50	1966	1638	124	1904	1696	44	30	M27	50	4	12	100	14	1568	113	794
	16													1552	98	818	
23	QN. 2000. 50	2166	1842	124	2104	1896	48	30	M27	50	6	12	100	16	1760	111	891
	18													1746	98	913	
24	QN. 2240. 50	2406	2078	124	2344	2136	54	30	M27	50	6	12	100	16	1984	125	1044
	18													1980	111	1041	
25	QN. 2500. 50	2666	2342	124	2604	2396	60	30	M27	50	6	12	100	18	2250	126	1132
	20													2240	113	1148	
26	QN. 2500. 60	2696	2308	150	2626	2374	60	33	M30	56	6	14	122	18	2214	124	1621
	20													2200	111	1654	

注:

- 1、n1为润滑油孔数，均布：油杯M10×1 JB/T7940.1-JB/T7940.2
- 2、安装孔n-Φ可改用螺孔；齿宽b可改为H-h。
- 3、表内齿轮圆周力为最大圆周力，额定圆周力取其1/2。